

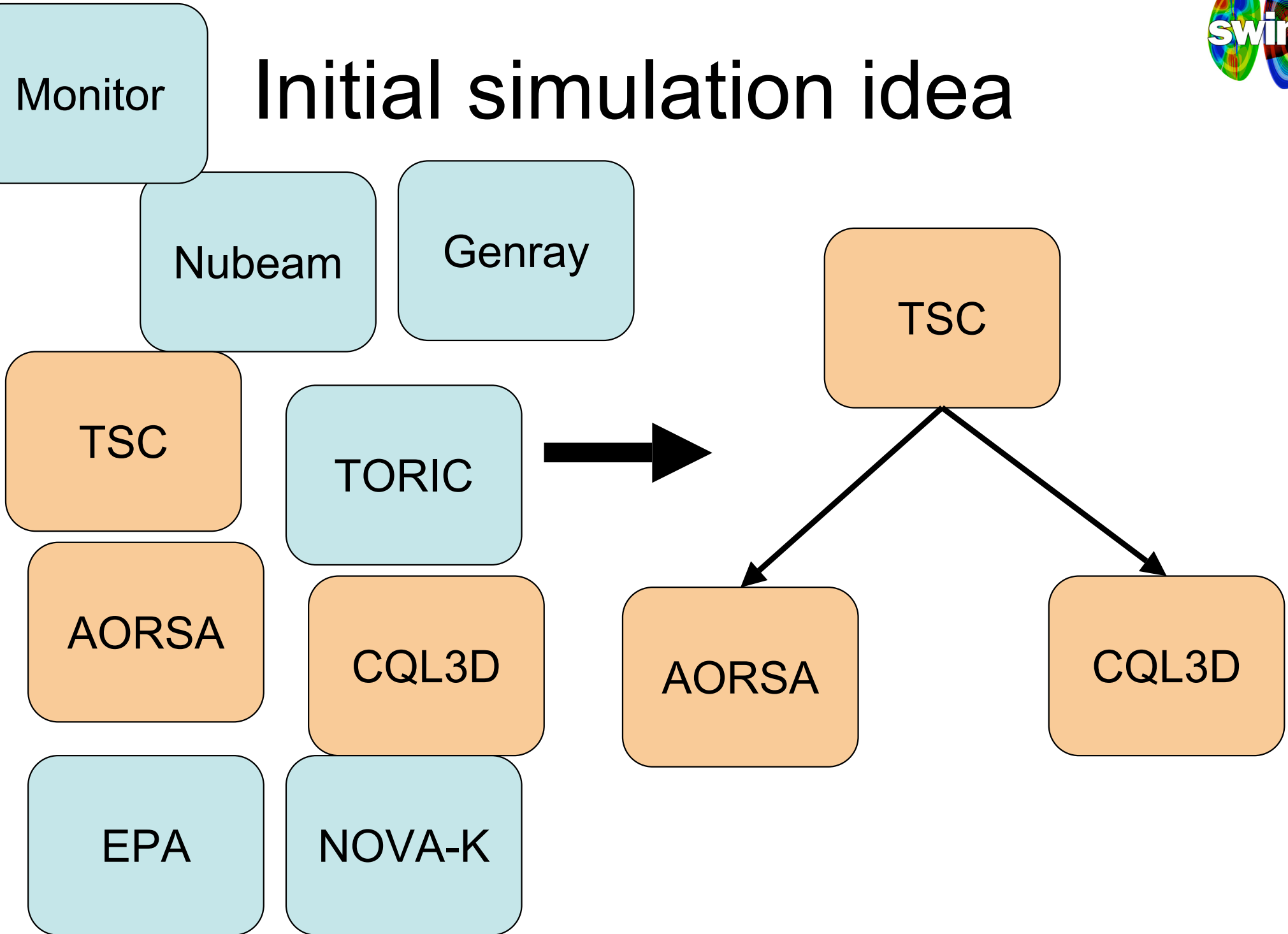

# Steps to compose a concurrent simulation run

- Gather components you want to use
- Figure out logical data dependencies
- Consider how concurrent execution can and should effect the runtime and resource needs of the simulation run
- Think about IPS interactions that are needed
- Write the driver and test it

# Initial simulation idea



# Time-Component Diagram

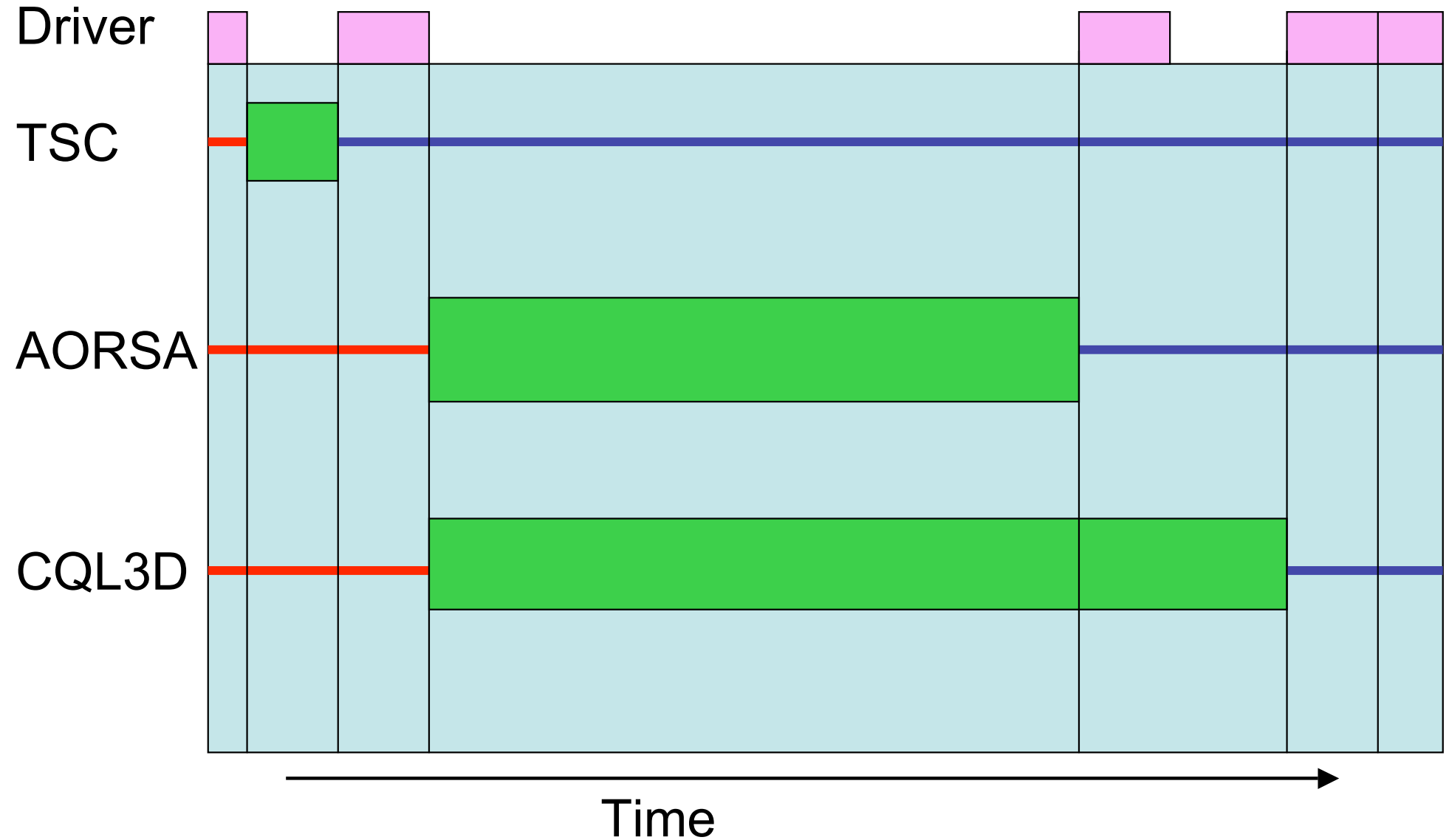

# IPS interactions

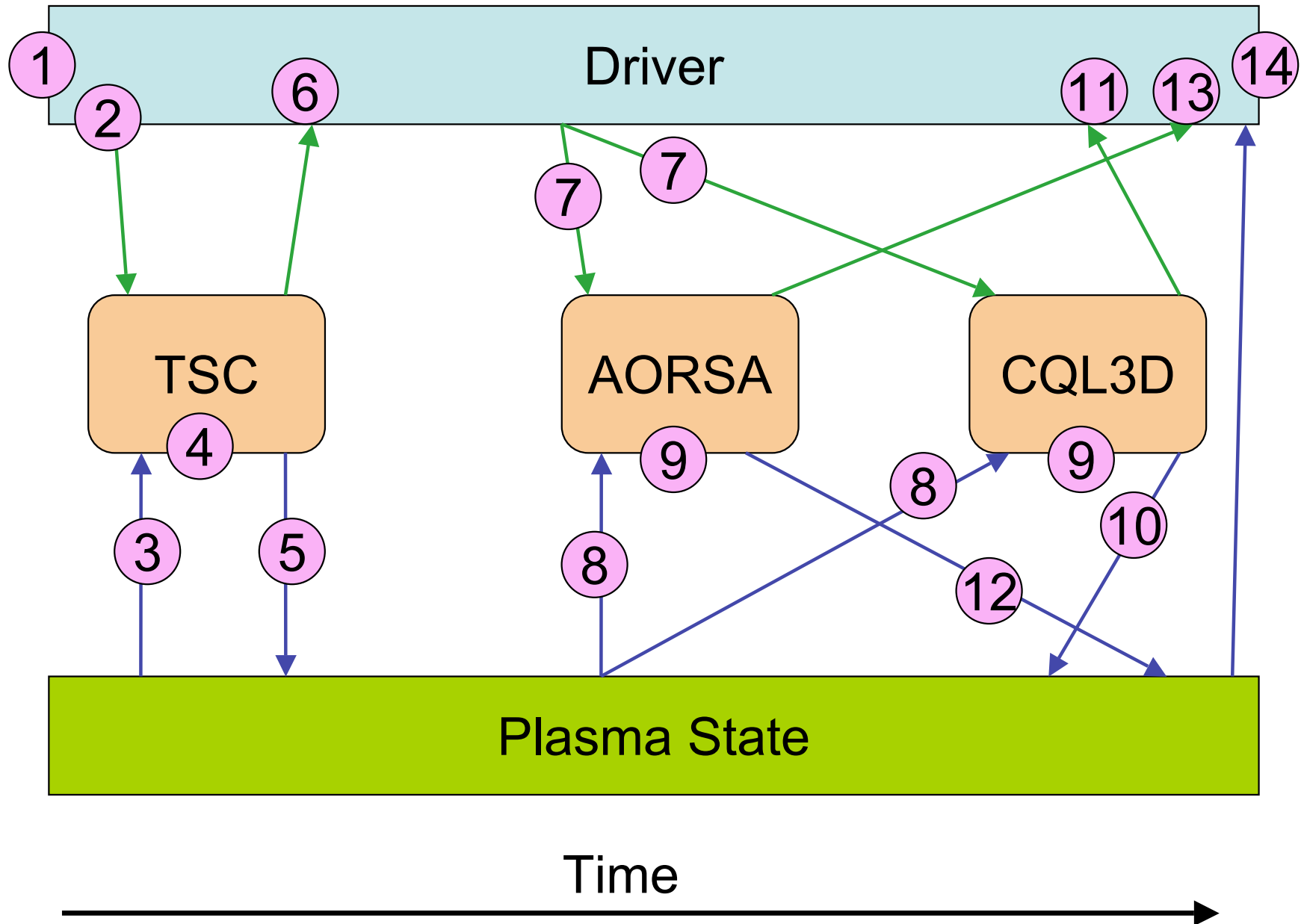

# Driver code



```
for t in timeloop:
```

```
    # launch tsc by itself
```

```
    tscRetVal = services.call(tscCompID, "step")
```

```
    # check return value, handle any problems
```

```
    # launch aorsa and cql3d concurrently
```

```
    aorsaCallID = services.callNonblocking(aorsaCompID, "step")
```

```
    cql3dCallID = services.callNonblocking(cql3dCompID, "step")
```

```
    aorsaRetVal = services.wait(aorsaCallID)
```

```
    # check return value, handle any problems
```

```
    cql3dRetVal = services.wait(cql3dCallID)
```

```
    # check return value, handle any problems
```

```
    # get latest version of plasma state
```

```
    services.stagePlasmaState()
```

```
    # write output files to well-known location,
```

```
    # including latest plasma state
```

```
    services.stageOutputFiles()
```